

Kideas

Sew Your Own Sling

Courtesy of Maya Wrap Baby Slings and Baby Carriers

CAUTION: If the rings are too thin, it is possible for one to pop through the other while you are using your sling. If this happens, your child will fall out and could be injured.



Not up to sewing? Buy your sling in a beautiful fabric such as this at www.mayawrap.com.

Materials:

- 2.25 - 2.5 yards fabric

- Two 3" sturdy metal or nylon rings.

* These rings may be available where cattle or sail boating supplies are sold.

* Rings may also be purchased on line at: elizabethlee.com and Slingrings.com

* Metal rings should be 4 gauge wire or thicker.

FABRIC CONSIDERATIONS:

Width: If you choose fabric that is 36 - 45" wide you will not need to hem the sides unless you choose to do so. If the fabric is wider than 45" you will have too much. (The Maya Wrap Sling is 35" wide.)

Pattern: Both sides of the fabric will show when you use your sling so you may want to choose a fabric that does not have a "wrong" side.

Type: Cotton or cotton/polyester blends are recommended. The rings may not be able to hold a slick fabric in place. You will sew a seam through many layers of fabric so choose a fabric your machine can handle or plan to sew this seam by hand.

Length: You will need 2 and 1/4 yards to make a size medium sling. If you are tall or large 2 and 1/2 yards is a good idea.

continued on next page...

Directions:

1. Hem, or surge one of the cut edges of the fabric.

2. Hem or surge the selvage edges. If the selvage edges look good, you may not have to finish them.

3. Fold the fabric like a fan as shown in figure 1. Make the folds 4" or 6" wide*. You do not need to make these folds the entire length of the fabric, 10-12" down from the top will be enough.

4. Surge or zigzag the remaining cut end, through all thicknesses of the folded fabric. Note: if you use a serger for this step, be sure that your serger can handle all of the thicknesses.

5. Put this folded end through the rings and pull it through 3 - 4 inches. Fold the fabric back on itself. Pin in place, but do not catch Panel 1.

6. Fold Panel 1 out of the way, and stitch through all thicknesses 1/4"-1/2" from cut edge, making sure not to sew through Panel 1**. This seam will take a lot of stress so it is important that it is a strong seam and that it is backstitched on both ends. It is recommended that you make two lines of stitching. Consider using upholstery thread and a heavy duty needle for this step.

**For people with large shoulders, we have found that 6" is a more comfortable width.*

***When you use your sling, you can unfold Panel 1 over your shoulder to create a Shoulder Cap. This will help to keep the sling in place and better spread your child's weight across your back.*

IMPORTANT: Completely read *Maya Wrap's safe use instructions before use, available at both www.kideas.com and www.mayawrap.com.*

Figure 1

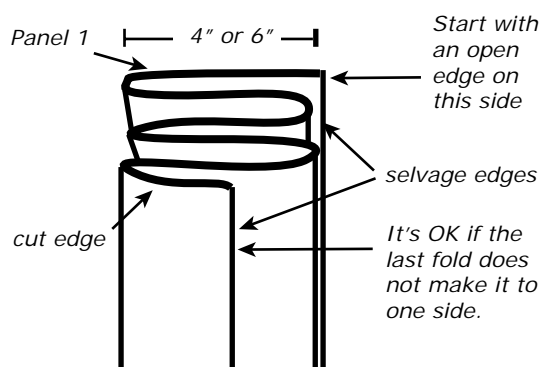

Figure 2

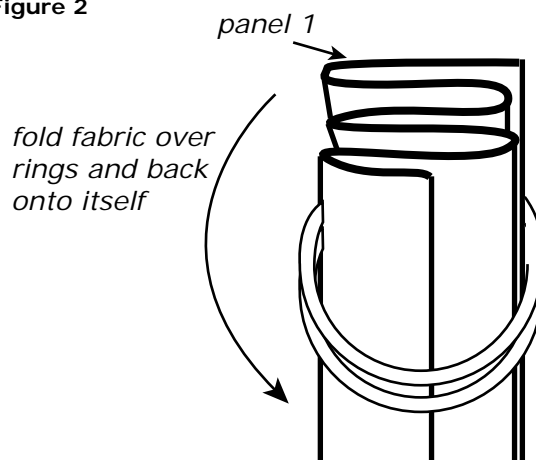

Figure 3

